

**Product Features:**

**Common Features:**

- PI74FCT16373T, PI74FCT162373T, and PI74FCT162H373T are high-speed, low power devices with high current drive.
- $V_{CC} = 5V \pm 10\%$
- Hysteresis on all inputs
- Packages available:
  - 48-pin 240 mil wide plastic TSSOP (A)
  - 48-pin 300 mil wide plastic SSOP (V)

**PI74FCT16373T Features:**

- High output drive:  $I_{OH} = -32 \text{ mA}$ ;  $I_{OL} = 64 \text{ mA}$
- Power off disable outputs permit "live insertion"
- Typical  $V_{OLP}$  (Output Ground Bounce)  $< 1.0V$  at  $V_{CC} = 5V$ ,  $T_A = 25^\circ C$

**PI74FCT162373T Features:**

- Balanced output drivers:  $\pm 24 \text{ mA}$
- Reduced system switching noise
- Typical  $V_{OLP}$  (Output Ground Bounce)  $< 0.6V$  at  $V_{CC} = 5V$ ,  $T_A = 25^\circ C$

**PI74FCT162H373T Features:**

- Bus Hold retains last active bus state during 3-state
- Eliminates the need for external pull-up resistors

**Product Description:**

Pericom Semiconductor's PI74FCT series of logic circuits are produced in the Company's advanced 0.6 micron CMOS technology, achieving industry leading speed grades.

The PI74FCT16373T, PI74FCT162373T, and PI74FCT162H373T are 16-bit transparent latches designed with 3-state outputs and are intended for bus oriented applications. The Output Enable and Latch Enable controls are organized to operate as two 8-bit latches or one 16-bit latch. When Latch Enable (LE) is HIGH, the flip-flops appear transparent to the data. The data that meets the set-up time when LE is LOW is latched. When  $\overline{OE}$  is HIGH, the bus output is in the high impedance state.

The PI74FCT16373T output buffers are designed with a Power-Off disable allowing "live insertion" of boards when used as backplane drivers.

The PI74FCT162373T has  $\pm 24 \text{ mA}$  balanced output drivers. It is designed with current limiting resistors at its outputs to control the output edge rate resulting in lower ground bounce and undershoot. This eliminates the need for external terminating resistors for most interface applications.

The PI74FCT162H373T has "Bus Hold" which retains the input's last state whenever the input goes to high-impedance preventing "floating" inputs and eliminating the need for pull-up/down resistors.

**Logic Block Diagram**

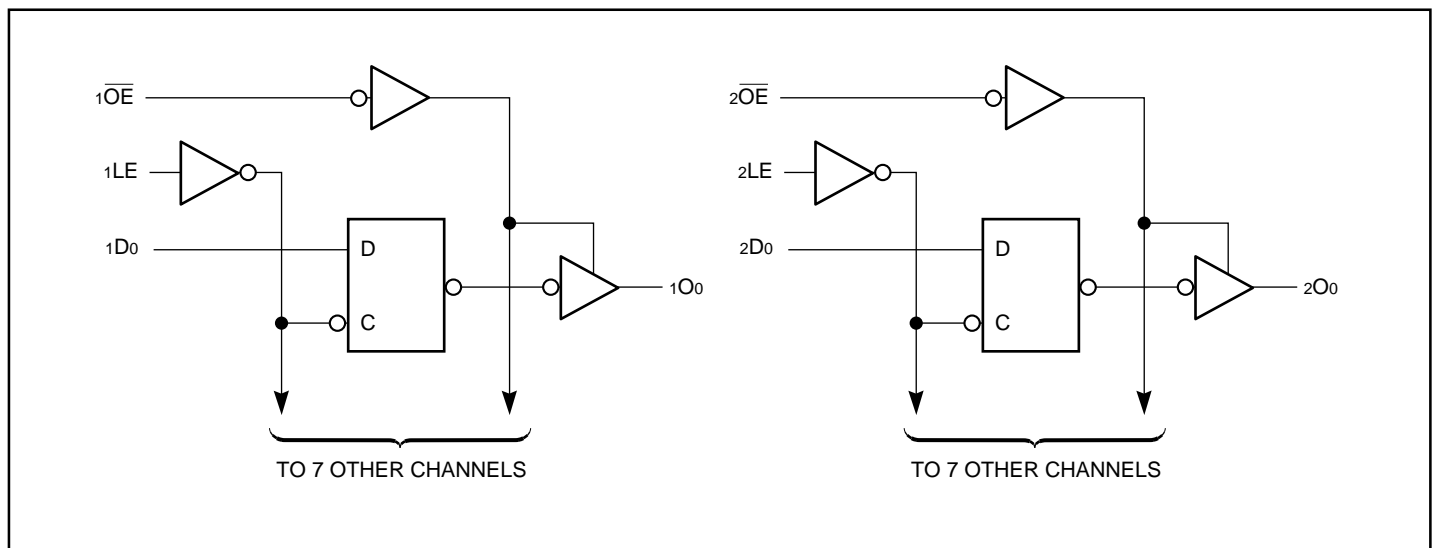

**Product Pin Description**

PinName	Description
$\overline{xOE}$	Output Enable Inputs (Active LOW)
$xLE$	Latch Enable Inputs (Active HIGH)
$xDx$	Inputs <sup>(1)</sup>
$xOx$	3-State Outputs
GND	Ground
VCC	Power

**Truth Table**

Inputs <sup>(1)</sup>			Outputs <sup>(1)</sup>
$xDx$	$\overline{xOE}$	$xLE$	$xOx$
H	L	H	H
L	L	H	L
X	H	X	Z

**Note:** 1. H = High Voltage Level, X = Don't Care, L = Low Voltage Level, Z = High Impedance

**Note:** 1. For the PI74FCT162H373T, these pins have "Bus Hold." All other pins are standard, outputs, or I/Os.

**Product Pin Configuration**

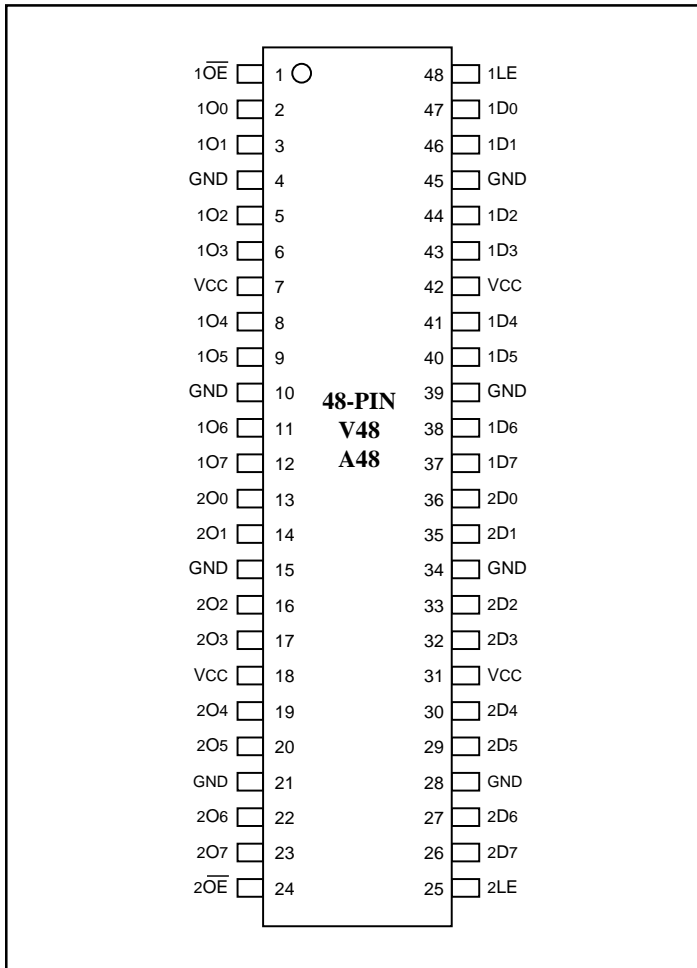

### Maximum Ratings

(Above which the useful life may be impaired. For user guidelines, not tested.)

Storage Temperature .....	-65°C to +150°C
Ambient Temperature with Power Applied .....	-40°C to +85°C
Supply Voltage to Ground Potential (Inputs & Vcc Only) .....	-0.5V to +7.0V
Supply Voltage to Ground Potential (Outputs & D/O Only) .....	-0.5V to +7.0V
DC Input Voltage .....	-0.5V to +7.0V
DC Output Current .....	120mA
Power Dissipation .....	1.0W

#### Note:

Stresses greater than those listed under MAXIMUM RATINGS may cause permanent damage to the device. This is a stress rating only and functional operation of the device at these or any other conditions above those indicated in the operational sections of this specification is not implied. Exposure to absolute maximum rating conditions for extended periods may affect reliability.

### DC Electrical Characteristics (Over the Operating Range, TA = -40°C to +85°C, VCC = 5.0V ± 10%)

Parameters	Description	Test Conditions <sup>(1)</sup>		Min.	Typ <sup>(2)</sup>	Max.	Units
V <sub>IH</sub>	Input HIGH Voltage	Guaranteed Logic HIGH Level		2.0			V
V <sub>IL</sub>	Input LOW Voltage	Guaranteed Logic LOW Level				0.8	V
I <sub>IH</sub>	Input HIGH Current	Standard Input, V <sub>CC</sub> = Max.	V <sub>IN</sub> = V <sub>CC</sub>			1	μA
I <sub>IH</sub>	Input HIGH Current	Standard I/O, V <sub>CC</sub> = Max.	V <sub>IN</sub> = V <sub>CC</sub>			1	μA
I <sub>IH</sub>	Input HIGH Current	Bus Hold Input <sup>(4)</sup> , V <sub>CC</sub> = Max.	V <sub>IN</sub> = V <sub>CC</sub>			±100	μA
I <sub>IH</sub>	Input HIGH Current	Bus Hold I/O <sup>(4)</sup> , V <sub>CC</sub> = Max.	V <sub>IN</sub> = V <sub>CC</sub>			±100	μA
I <sub>IL</sub>	Input LOW Current	Standard Input, V <sub>CC</sub> = Min.	V <sub>IN</sub> = GND			-1	μA
I <sub>IL</sub>	Input LOW Current	Standard I/O, V <sub>CC</sub> = Min.	V <sub>IN</sub> = GND			-1	μA
I <sub>IL</sub>	Input LOW Current	Bus Hold Input <sup>(4)</sup> , V <sub>CC</sub> = Min.	V <sub>IN</sub> = GND			±100	μA
I <sub>IL</sub>	Input LOW Current	Bus Hold I/O <sup>(4)</sup> , V <sub>CC</sub> = Min.	V <sub>IN</sub> = GND			±100	μA
I <sub>BHH</sub>	Bus Hold Sustain Current	Bus Hold Input <sup>(4)</sup> , V <sub>CC</sub> = Min.	V <sub>IN</sub> = 2.0V	-50			μA
I <sub>BHL</sub>			V <sub>IN</sub> = 0.8V	+50			
I <sub>OZH</sub> <sup>(5)</sup>	High Impedance	V <sub>CC</sub> = Max.	V <sub>OUT</sub> = 2.7V			1	μA
I <sub>OZL</sub> <sup>(5)</sup>	Output Current	V <sub>CC</sub> = Max.	V <sub>OUT</sub> = 0.5V			-1	μA
V <sub>IK</sub>	Clamp Diode Voltage	V <sub>CC</sub> = Min., I <sub>IN</sub> = -18 mA			-0.7	-1.2	V
I <sub>OS</sub>	Short Circuit Current	V <sub>CC</sub> = Max. <sup>(3)</sup> , V <sub>OUT</sub> = GND		-80	-140	-200	mA
I <sub>O</sub>	Output Drive Current	V <sub>CC</sub> = Max. <sup>(3)</sup> , V <sub>OUT</sub> = 2.5V		-50		-180	mA
V <sub>H</sub>	Input Hysteresis				100		mV

#### Notes:

1. For Max. or Min. conditions, use appropriate value specified under Electrical Characteristics for the applicable device type.
2. Typical values are at V<sub>CC</sub> = 5.0V, +25°C ambient and maximum loading.
3. Not more than one output should be shorted at one time. Duration of the test should not exceed one second.
4. Pins with Bus Hold are identified in the pin description.
5. This specification does not apply to bi-directional functionalities with Bus Hold.

**PI74FCT16373T Output Drive Characteristics** (Over the Operating Range)

Parameters	Description	Test Conditions <sup>(1)</sup>		Min.	Typ <sup>(2)</sup>	Max.	Units
VOH	Output HIGH Voltage	VCC = Min., VIN = VIH or VIL	IOH = -3.0 mA	2.5	3.5		V
			IOH = -15.0 mA	2.4	3.5		
			IOH = -32.0 mA	2.0	3.0		
VOL	Output LOW Voltage	VCC = Min., VIN = VIH or VIL	IOL = 64 mA		0.2	0.55	V
IOFF	Power Down Disable	VCC = 0V, VIN or VOUT ≤ 4.5V		—	—	±100	μA

**PI74FCT162373T/162H373T Output Drive Characteristics** (Over the Operating Range)

Parameters	Description	Test Conditions <sup>(1)</sup>		Min.	Typ <sup>(2)</sup>	Max.	Units
VOH	Output HIGH Voltage	VCC = Min., VIN = VIH or VIL	IOH = -24.0 mA	2.4	3.3		V
VOL	Output LOW Voltage	VCC = Min., VIN = VIH or VIL	IOL = 24 mA		0.3	0.55	V
IODL	Output LOW Current	VCC = 5V, VIN = VIH or VIL, VOUT = 1.5V <sup>(3)</sup>		60	115	150	mA
IODH	Output HIGH Current	VCC = 5V, VIN = VIH or VIL, VOUT = 1.5V <sup>(3)</sup>		-60	-115	-150	mA

**Capacitance** (TA = 25°C, f = 1 MHz)

Parameters <sup>(4)</sup>	Description	Test Conditions	Typ	Max.	Units
CIN	Input Capacitance	VIN = 0V	4.5	6	pF
COUT	Output Capacitance	VOUT = 0V	5.5	8	pF

**Notes:**

1. For Max. or Min. conditions, use appropriate value specified under Electrical Characteristics for the applicable device type.
2. Typical values are at VCC = 5.0V, +25°C ambient and maximum loading.
3. Not more than one output should be shorted at one time. Duration of the test should not exceed one second.
4. This parameter is determined by device characterization but is not production tested.

**Power Supply Characteristics**

Parameters	Description	Test Conditions <sup>(1)</sup>		Min.	Typ <sup>(2)</sup>	Max.	Units
I <sub>CC</sub>	Quiescent Power Supply Current	V <sub>CC</sub> = Max.	V <sub>IN</sub> = GND or V <sub>CC</sub>		0.1	500	μA
ΔI <sub>CC</sub>	Supply Current per Input @ TTL HIGH	V <sub>CC</sub> = Max.	V <sub>IN</sub> = 3.4V <sup>(3)</sup>		0.5	1.5	mA
I <sub>CCD</sub>	Supply Current per Input per MHz <sup>(4)</sup>	V <sub>CC</sub> = Max., Outputs Open x $\overline{OE}$ = GND, xLE = V <sub>CC</sub> One Bit Toggling 50% Duty Cycle	V <sub>IN</sub> = V <sub>CC</sub> V <sub>IN</sub> = GND		60	100	μA/ MHz
I <sub>C</sub>	Total Power Supply Current <sup>(6)</sup>	V <sub>CC</sub> = Max., Outputs Open f <sub>i</sub> = 10 MHz 50% Duty Cycle x $\overline{OE}$ = GND, xLE = V <sub>CC</sub> One Bit Toggling	V <sub>IN</sub> = V <sub>CC</sub> V <sub>IN</sub> = GND		0.6	1.5 <sup>(5)</sup>	mA
			V <sub>IN</sub> = 3.4V V <sub>IN</sub> = GND		0.9	2.3 <sup>(5)</sup>	
		V <sub>CC</sub> = Max., Outputs Open f <sub>i</sub> = 2.5 MHz 50% Duty Cycle x $\overline{OE}$ = GND, xLE = V <sub>CC</sub> 16 Bits Toggling	V <sub>IN</sub> = V <sub>CC</sub> V <sub>IN</sub> = GND		2.4	4.5 <sup>(5)</sup>	
			V <sub>IN</sub> = 3.4V V <sub>IN</sub> = GND		6.4	16.5 <sup>(5)</sup>	

**Notes:**

- For conditions shown as Max. or Min., use appropriate value specified under Electrical Characteristics for the applicable device.
- Typical values are at V<sub>CC</sub> = 5.0V, +25°C ambient.
- Per TTL driven input (V<sub>IN</sub> = 3.4V); all other inputs at V<sub>CC</sub> or GND.
- This parameter is not directly testable, but is derived for use in Total Power Supply Calculations.
- Values for these conditions are examples of the I<sub>CC</sub> formula. These limits are guaranteed but not tested.
- I<sub>C</sub> = I<sub>QUIESCENT</sub> + I<sub>INPUTS</sub> + I<sub>DYNAMIC</sub>  
 $I_C = I_{CC} + \Delta I_{CC} D_H N_T + I_{CCD} (f_{CP}/2 + f_i N_i)$   
 I<sub>CC</sub> = Quiescent Current  
 ΔI<sub>CC</sub> = Power Supply Current for a TTL High Input (V<sub>IN</sub> = 3.4V)  
 D<sub>H</sub> = Duty Cycle for TTL Inputs High  
 N<sub>T</sub> = Number of TTL Inputs at D<sub>H</sub>  
 I<sub>CCD</sub> = Dynamic Current Caused by an Input Transition Pair (HLH or LHL)  
 f<sub>CP</sub> = Clock Frequency for Register Devices (Zero for Non-Register Devices)  
 f<sub>i</sub> = Input Frequency  
 N<sub>i</sub> = Number of Inputs at f<sub>i</sub>  
 All currents are in milliamps and all frequencies are in megahertz.

**PI74FCT16373T Switching Characteristics over Operating Range**

Parameters	Description	Conditions <sup>(1)</sup>	16373T		16373AT		16373CT		16373DT		16373ET		Unit
			Com.		Com.		Com.		Com.		Com.		
			Min	Max	Min	Max	Min	Max	Min	Max	Min	Max	
tPLH tPHL	Propagation Delay xDx to xOx	CL = 50 pF RL = 500Ω	1.5	8.0	1.5	5.2	1.5	4.2	1.5	3.8	1.5	3.4	ns
tPLH tPHL	Propagation Delay xLE to xOx		2.0	13.0	2.0	8.5	2.0	5.5	1.5	4.0	1.5	3.7	ns
tpZH tpZL	Output Enable Time xOE to xOx		1.5	12.0	1.5	6.5	1.5	5.5	1.5	4.8	1.5	4.4	ns
tpHZ tPLZ	Output Disable Time <sup>(3)</sup> xOE to xOx		1.5	7.5	1.5	5.5	1.5	5.0	1.5	4.0	1.5	4.0	ns
tsU	Setup Time HIGH or LOW, xDx to xLE		2.0	—	2.0	—	2.0	—	1.5	—	1.0	—	ns
th	Hold Time HIGH or LOW, xDx to xLE		1.5	—	1.5	—	1.5	—	1.0	—	1.0	—	ns
tw	xLE Pulse Width HIGH <sup>(3)</sup>		6.0	—	5.0	—	5.0	—	3.0	—	3.0	—	ns
tsk(o)	Output Skew <sup>(4)</sup>		—	0.5	—	0.5	—	0.5	—	0.5	—	0.5	ns

**PI74FCT162373T Switching Characteristics over Operating Range**

Parameters	Description	Conditions <sup>(1)</sup>	162373T		162373AT		162373CT		162373DT		162373ET		Unit
			Com.		Com.		Com.		Com.		Com.		
			Min	Max	Min	Max	Min	Max	Min	Max	Min	Max	
tPLH tPHL	Propagation Delay xDx to xOx	CL = 50 pF RL = 500Ω	1.5	8.0	1.5	5.2	1.5	4.2	1.5	3.8	1.5	3.4	ns
tPLH tPHL	Propagation Delay xLE to xOx		2.0	13.0	2.0	8.5	2.0	5.5	1.5	4.0	1.5	3.7	ns
tpZH tpZL	Output Enable Time xOE to xOx		1.5	12.0	1.5	6.5	1.5	5.5	1.5	4.8	1.5	4.4	ns
tpHZ tPLZ	Output Disable Time <sup>(3)</sup> xOE to xOx		1.5	7.5	1.5	5.5	1.5	5.0	1.5	4.0	1.5	4.0	ns
tsU	Setup Time HIGH or LOW, xDx to xLE		2.0	—	2.0	—	2.0	—	1.5	—	1.0	—	ns
th	Hold Time HIGH or LOW, xDx to xLE		1.5	—	1.5	—	1.5	—	1.0	—	1.0	—	ns
tw	xLE Pulse Width HIGH <sup>(3)</sup>		6.0	—	5.0	—	5.0	—	3.0	—	3.0	—	ns
tsk(o)	Output Skew <sup>(4)</sup>		—	0.5	—	0.5	—	0.5	—	0.5	—	0.5	ns

**Notes:**

1. See test circuit and wave forms.
2. Minimum limits are guaranteed but not tested on Propagation Delays.
3. This parameter is guaranteed but not production tested.
4. Skew between any two outputs, of the same package, switching in the same direction. This parameter is guaranteed by design.

**PI74FCT162H373T Switching Characteristics over Operating Range**

Parameters	Description	Conditions <sup>(1)</sup>	162H373T		162H373AT		162H373CT		162H373DT		162H373ET		Unit
			Com.		Com.		Com.		Com.		Com.		
			Min	Max	Min	Max	Min	Max	Min	Max	Min	Max	
tPLH tPHL	Propagation Delay xDx to xOx	CL = 50 pF RL = 500Ω	1.5	8.0	1.5	5.2	1.5	4.2	1.5	3.8	1.5	3.4	ns
tPLH tPHL	Propagation Delay xLE to xOx		2.0	13.0	2.0	8.5	2.0	5.5	1.5	4.0	1.5	3.7	ns
tpZH tpZL	Output Enable Time xOE to xOx		1.5	12.0	1.5	6.5	1.5	5.5	1.5	4.8	1.5	4.4	ns
tpHZ tplZ	Output Disable Time <sup>(3)</sup> xOE to xOx		1.5	7.5	1.5	5.5	1.5	5.0	1.5	4.0	1.5	4.0	ns
tsU	Setup Time HIGH or LOW, xDx to xLE		2.0	—	2.0	—	2.0	—	1.5	—	1.0	—	ns
th	Hold Time HIGH or LOW, xDx to xLE		1.5	—	1.5	—	1.5	—	1.0	—	1.0	—	ns
tw	xLE Pulse Width HIGH <sup>(3)</sup>		6.0	—	5.0	—	5.0	—	3.0	—	3.0	—	ns
tsk(o)	Output Skew <sup>(4)</sup>		—	0.5	—	0.5	—	0.5	—	0.5	—	0.5	ns

**Notes:**

1. See test circuit and wave forms.
2. Minimum limits are guaranteed but not tested on Propagation Delays.
3. This parameter is guaranteed but not production tested.
4. Skew between any two outputs, of the same package, switching in the same direction. This parameter is guaranteed by design.